

SECTIONAL ELEVATION VIEW

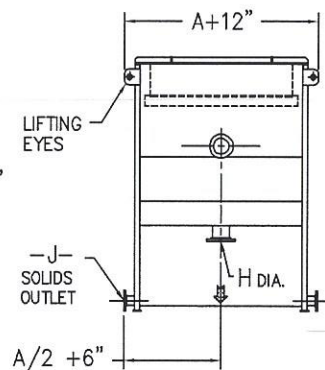

END VIEW

MODEL UNIT	OCS-50	OCS-100	OCS-150	OCS-200	OCS-250	OCS-300
HYDRAULIC CAPACITY GAL/DAY	72,000	144,000	216,000	288,000	360,000	432,000
COALESCING AREA FT ²	1150	2300	3840	4600	6140	6910
NO. OF FRAME PACKS	1	1	1	2	2	2
SLUDGE CAPACITY GALLONS	53	70	88	106	141	159
OIL RESEVOIR CAP. GALLONS	23	48	65	70	98	146
OIL SPECIFIC GRAVITY	.85	.85	.85	.85	.85	.85
MAXIMUM TEMPERATURE	140	140	140	140	140	140
OPERATING WEIGHT LBS.	6000	10,000	15,500	18,000	24,000	27,000

GENERAL NOTES:

- 1.) ALL EXTERNAL PIPING TO THE COUPLINGS IN THE SIDE OF TANK FOR THE SOLIDS, OIL REMOVAL & VENT PIPES ARE BY OTHERS.
- 2.) FOUNDATION PAD MUST BE LEVEL TO WITHIN 1/8" IN BOTH DIRECTIONS
- 3.) LOCATION ELEVATION AND POSITION MUST BE VERIFIED BEFORE ANCHORING OF TANK TO THE FOUNDATION PAD.

MATERIAL NOTES:

- 1.) TANK TO BE FABRICATED W/ MINIMUM OF 1/4" THICK, USING ASTM A-36 PLATE
- 2.) TANK INTERIOR TO BE SANDBLASTED TO (SSPC-SP10) NEAR WHITE FOLLOWED BY PAINTING WITH ONE (1) COAT 8-12 DFT OF TNEC SERIES 66 HIGH BUILD EPOXY (GRAY COLOR)
TANK EXTERIOR TO BE SANDBLASTED TO (SSPC-SR6) COMMERCIAL BLAST CLEANING FOLLOWED BY PAINTING WITH ONE (1) COAT OF 8-12 DFT OF TNEC SERIES 66 HIGH BUILD EPOXY (GRAY COLOR)
- 3.) COALESCING MEDIA TO BE 10 MIL. PVC CROSS CORRUGATED, MAX TEMP. 140° F.

MODEL	A	B	C	D	E	F	G	H	J
OCS-50	2'-1"	12'-1"	6'-9 1/2"	5'-6"	2'-2 1/2"	4'-1"	4"	3"	3"
OCS-100	4'-1"	12'-1"	6'-9 1/2"	5'-6"	2'-2 1/2"	4'-1"	4"	3"	3"
OCS-150	5'-1"	12'-1"	7'-9 1/2"	5'-6"	2'-2 1/2"	4'-2"	6"	3"	4"
OCS-200	6'-1"	12'-1"	7'-9 1/2"	5'-6"	2'-2 1/2"	4'-2"	6"	3"	4"
OCS-250	8'-1"	12'-1"	7'-9 1/2"	5'-6"	2'-2 1/2"	4'-3"	8"	4"	6"
OCS-300	9'-1"	12'-1"	7'-9 1/2"	5'-6"	2'-2 1/2"	4'-3"	8"	4"	6"

REV.	DATE	DESCRIPTION	APPROV.
11/24/14		DELETED MODELS 15 & 30 FROM CHART	JJM
4/18/09		UPDATED CHART FOR OCS-50 & 15	JJM

PCS Pollution Control Systems, Inc.

5827 Happy Hollow Rd, Suite 1B
Milford, Ohio 45150
Ph: (513) 831-1165 Fx: (513) 965-4812
E-mail: PolConSys@aol.com

THIS DRAWING CONTAINS INFORMATION THAT IS PROPRIETARY TO POLLUTION CONTROL SYSTEMS AND IS NOT TO BE USED WITHOUT PERMISSION OF POLLUTION CONTROL SYSTEMS

50-300 GPM OIL COALESCING SEPARATORS

SCALE: 1/4"=1'-0" (OCS-150)	QUOTE NO.	PROJECT NO.
DRAWN BY: JJM	DATE: 12/30/99	SHEET: DRAWING NO.
CHECKED BY: JJM	DATE: 12/30/99	1 OF 1 OCS-1

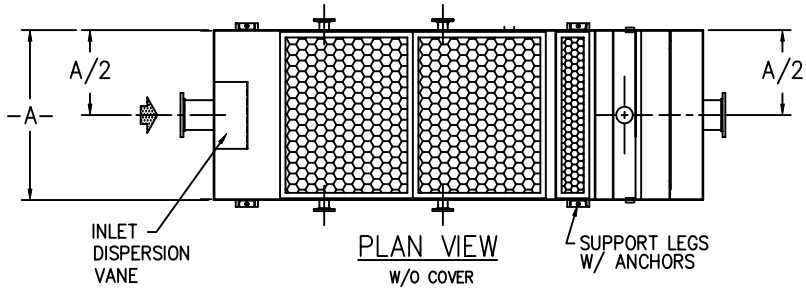

MODEL UNIT	OCS-400	OCS-500	OCS-750	OCS-1000	OCS-1250
HYDRAULIC CAPACITY GAL/DAY	576,000	720,000	1,080,000	1,440,000	1,800,000
COALESCING AREA FT ²	9600	12,200	18,432	24,576	27,648
NO. OF FRAME PACKS	2	4	8	8	12
SLUDGE CAPACITY GALLONS	230	350	350	475	535
OIL RESEVOIR CAP. GALLONS	104	128	200	325	435
OIL SPECIFIC GRAVITY	.85	.85	.85	.85	.85
MAXIMUM TEMPERATURE	140	140	140	140	140
APPROX. OPERATING WEIGHT LBS	35,500	46,500	60,500	75,500	90,500

GENERAL NOTES:

- 1.) ALL EXTERNAL PIPING TO THE COUPLINGS IN THE SIDE OF TANK FOR THE SOLIDS, OIL REMOVAL & VENT PIPES ARE BY OTHERS.
- 2.) FOUNDATION PAD MUST BE LEVEL TO WITHIN 1/8" ALL AROUND
- 3.) LOCATION ELEVATION AND POSITION MUST BE VERIFIED BEFORE ANCHORING TANK TO THE FOUNDATION OR HOUSEKEEPING PAD.

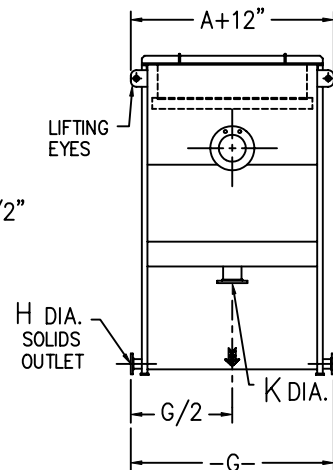
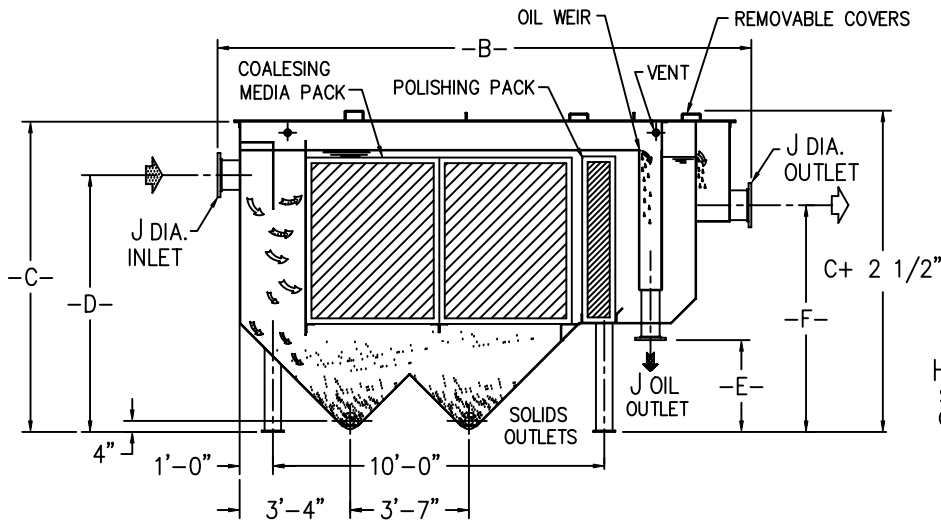

SECTIONAL ELEVATION VIEW

END VIEW

MATERIAL NOTES:

- 1.) TANK SHELL TO BE FABRICATED W/ MINIMUM OF 1/4" THICK STEEL USING ASTM A-36 PLATE
- 2.) TANK INTERIOR TO BE SANDBLASTED TO (SSPC-SP10) NEAR WHITE FOLLOWED BY PAINTING WITH ONE (1) COAT 8-12 DFT OF TNEMEC SERIES 66 HIGH BUILD EPOXY (GRAY COLOR)
TANK EXTERIOR TO BE SANDBLASTED TO (SSPC-SR6) COMMERCIAL BLAST CLEANING FOLLOWED BY PAINTING WITH ONE (1) COAT OF 8-12 DFT OF TNEMEC SERIES 66 HIGH BUILD EPOXY (GRAY COLOR)
- 3.) COALESCING MEDIA TO BE 10 MIL. THICK PVC CROSS CORRUGATED, W/ MAX TEMP. RATING OF 140° F.

MODEL	A	B	C	D	E	F	G	H	J	K
OCS-400	5'-1 1/2"	16'-1"	11'-4 1/2"	7'-9"	2'-9 1/4"	6'-10"	6'-1 1/2"	4"	10"	6"
OCS-500	8'-1 1/2"	16'-1"	11'-4 1/2"	6'-9"	2'-9 1/4"	5'-10"	8'-1 1/2"	4"	10"	6"
OCS-750	8'-1 1/2"	16'-1"	10'-4"	8'-9"	2'-9 1/4"	7'-11"	8'-1 1/2"	4"	12"	6"
OCS-1000	8'-1 1/2"	16'-1"	8'-4 1/2"	9'-9"	4'-3"	9'-0"	9'-1 1/2"	4"	14"	6"
OCS-1250	9'-2"	16'-1"	9'-4 1/2"	9'-9"	4'-3"	9'-1"	10'-0"	4"	16"	6"

REV.	DATE	DESCRIPTION	APPROV.

PCS Pollution Control Systems, Inc.
 5827 Happy Hollow Rd, Suite 1B
 Milford, Ohio 45150
 Ph: (513) 831-1165 Fx: (513) 965-4812
 E-mail: PolConSys@aol.com

THIS DRAWING CONTAINS INFORMATION THAT IS PROPRIETARY TO POLLUTION CONTROL SYSTEMS AND IS NOT TO BE USED WITHOUT PERMISSION OF POLLUTION CONTROL SYSTEMS

400-1250 GPM OIL COALESCING SEPARATOR

SCALE: 1/4"=1'-0" (OCS-400) QUOTE NO. PROJECT NO.

DRAWN BY: JJM DATE: 1/3/00 SHEET DRAWING NO.
 CHECKED BY: JJM DATE: 1/3/00 1 OF 1 OCS-2